

Emergency Disk- LED

user manual



Thank you for purchasing our LED emergency light. Be assured that our products have been designed according to the relevant standards below and if installed and maintained correctly they will provide long life service.

BS EN 60598-1 / BS EN 60598-2-22 / BS EN 50172 / BS EN 1838 / BS EN 62034

Installation/maintenance/servicing notes:

- Read the instructions before mounting/installation and hand it over to the customer for storage after installation.
- Luminaires should only be installed by qualified personnel.
- This product is configured as non-maintained. This means that it only switches on in case of failure of the power supply. Maintained mode is possible. Refer to installation and mounting on the following page.
- The LED light source and control gear are non-replaceable. Once end-of-life is reached, the whole luminaire will need to be replaced.
- In case of mains supply failure, the battery will automatically energise the emergency light for a minimum of 3 hours. After 3 hours 5 minutes the luminaire will enter into stand-by mode to prevent battery over-discharge. The battery must be recharged again no later than 6 months after mains supply's failure.
- Self-test emergency luminaires are programmed to carry out functional and full duration tests according to DIN EN 50172:2004.
- First battery charge takes up to 16 hrs.
- Battery re-charge takes up to 8hrs. Note that full cycle (discharge and recharge) takes up to 12 hours.
- Contact Z10 Safety if a battery replacement is required.
- This product is subject to Z10 Safety's Warranty Policy.

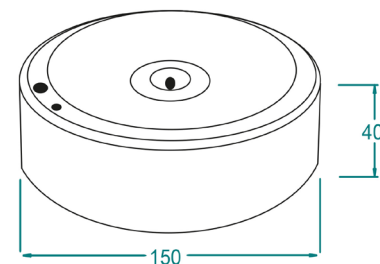

AST (Advanced Self-Test)

This is a self-test luminaire. Functional test is carried out automatically once a week and runs for 30 seconds. Full duration test is carried out automatically every 52 weeks. First full duration test is carried out automatically within the first 4 weeks after the luminaire being connected to mains voltage. This luminaire can be used in conjunction with the Advanced Remote Control (ARC). ARC IR Remote control is an optional tool that adds extra features to AST emergency luminaires. Please refer to the ARC's user guide.

Coding „LED indicator status“:

Green LED	Red LED	G	R	Status	Action required
Solid ON	OFF	●	○	OK	-
Normal Flash	OFF	⊙	○	Charging	-
OFF	Solid ON	○	●	Battery disconnected / Duration test failure	Connect battery/ Replace battery
Fast Flash	OFF	⊙	○	Functional/Duration test in progress	-
Normal Flash	Normal Flash	⊙	⊙	Battery temperature	Consult with Z10 Safety
OFF	Normal Flash	○	⊙	Light source fault	Replace Luminaire
Fast Flash	Fast Flash	⊙	⊙	PST clock unsync	Consult with Z10 Safety

⊙ Normal flash = 1Hz (about once/second)

⊙ Fast flash = 2Hz (about twice/second)

Emergency Disk - LED

Installation and mounting:

Step 1: Switch mains supply off.

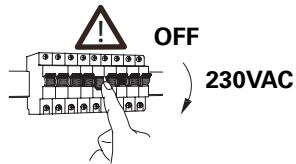

Ensure that the mains supply is switched off before installing.

Step 2: Open the Luminaire.

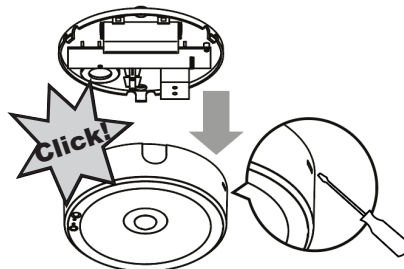

Use screwdriver to press the small hole on the side, then pull up the mounting base.

Step 3: Fix mounting base.

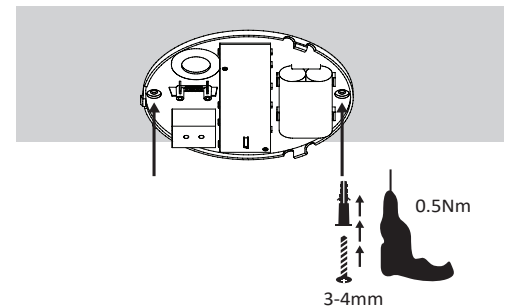

Drill where indicated and use wall plugs and screws, to fix the mounting base in the desired position.

Step 4: Cable size and strip length.

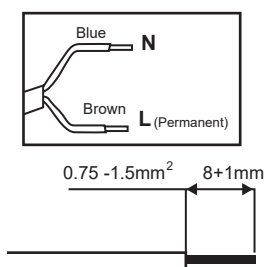

Step 5: Electrical connection.

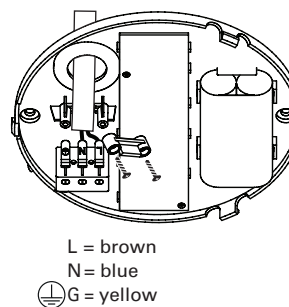

Secure mains cable using cable clip and screws.

Step 6: Battery label.

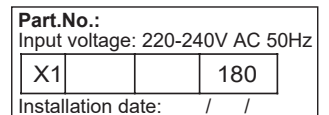

Write installation date on the Label.

Step 7: Fix the front part on the mounting base.

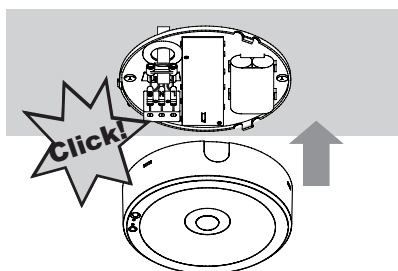

Step 8: Switch the mains supply on.

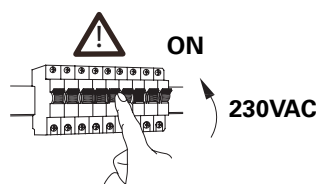

Disposal instructions:

According to the European WEEE directive, electrical and electronic equipment must not be disposed with consumer waste. Its components must be recycled or disposed apart from each other. Otherwise contaminative and hazardous substances can pollute our environment.

You as a consumer are committed by law to dispose electrical and electronic devices to the producer, the dealer, or public collecting points at the end of the devices lifetime for free. Particulars are regulated in national right.

The symbol on the product, in the user's manual, or at the packaging alludes to these terms.

With this kind of waste separation, application, and waste disposal of used devices you make an important contribution to environmental protection.

**AST
Test**

